

® **SIDE-
POWER**

**SE 60/185 S
Ignition Protected
thruster assembly**

Keep this
manual onboard !

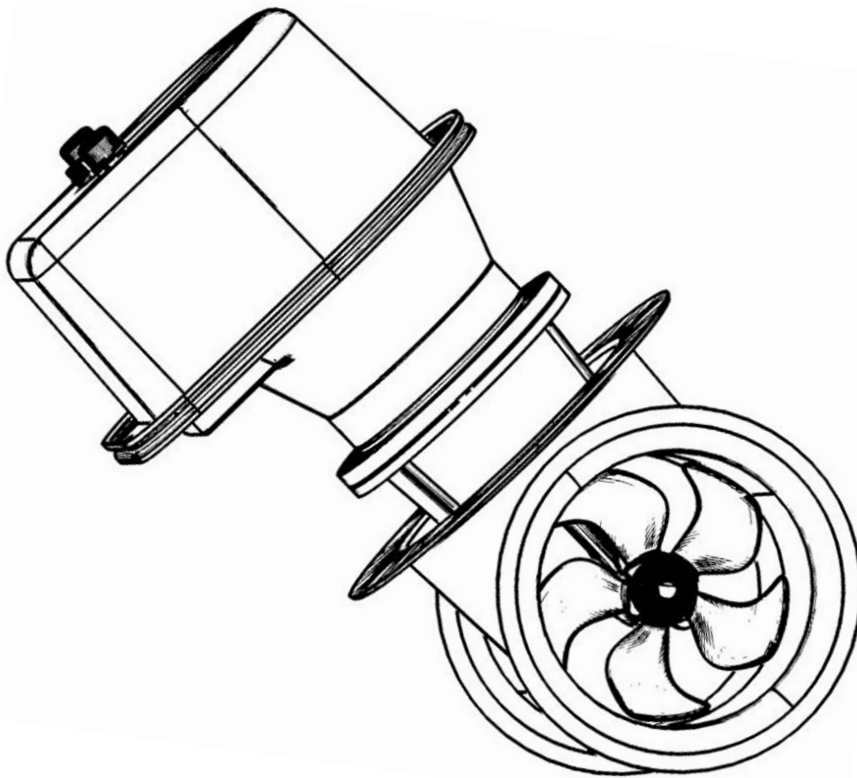

Installation and user manual



SLEIPNER MOTOR AS

P.O. Box 519
N-1612 Fredrikstad
Norway
Tel: +47 69 30 00 60
Fax: +47 69 30 00 70

www.side-power.com
sidepower@sleipner.no



Made in Norway

Contents

Technical specifications.....	2
Planning & important precautions.....	3
Stern thruster installation considerations.....	3
Bolt on installation.....	4
Mould on installation.....	5
Gearhouse and motorbracket.....	6
Oil tank & propellers.....	7
Electromotor IP assembly.....	8
Electrical installation.....	9
Control panel and control-leads.....	10
Visual wiring diagram.....	11
Technical wiring diagram.....	12
Electrical installation of stern thruster systems.....	12
Checklist.....	13
Important user precautions.....	14
How to use Sidepower thrusters.....	15
Maintenance.....	16
Troubleshooting.....	17
Warranty statement.....	18
Parts list.....	19
Service centres.....	20

DECLARATION OF CONFORMITY



We, Sleipner Motor AS
P.O. Box 519
N-1612 Fredrikstad, Norway

declare that this product with accompanying standard remote control systems complies with the essential health and safety requirements according to the Directive 89/336/EEC of 23 May 1989 amended by 92/31/EEC and 93/68/EEC.

Technical specifications

- Motor:** Custom made reversible DC-motor.
- Gearhouse:** Seawater resistant bronze. Ballbearing at propellershaft; combination of ballbearing and slide bearing at driveshaft.
- Motor bracket:** Seawaterresistant aluminium.
- Ignition protection:** Conforms to ISO 8846
- Propeller:** 5-blade Skew-back design "Q-prop" propeller, reinforced composite.
- Batteries:** Minimum recommended battery capacity (cold crank capacity by DIN standard)
SE60/185S 12V : 350 CCA DIN / 24V : 175 CCA DIN
- Max. use:** *S2 = 3 min. or appr. 7-10% within a limited time frame. All electromotors are protected against overheating.*
- Safety:** Electronic time-lapse device protects against sudden change of drive direction. Electric thermal cut-off switch in electromotor protects against over heating (auto reset when electro motor cools down).
Shearpin between electro-motor and driveshaft protects electromotor and gearsystem if propeller gets jammed.
If original Sidepower panel is used, the panel shuts off automatically 6 minutes after last use.
Integrated microprocessor monitors solenoids, reducing wear and risk of solenoid lock-in. Auto-stop of thruster in case of accidental solenoid lock-in or if run signal is continuous for more than 3 minutes.

Measurements ref. mm / inch	SE60/185S
A	265mm / 10,43"
B	256mm / 10,08"
C	150mm / 5,91"
D	337mm / 13,3"
E	ø300mm / 11,8"
F	ø200mm / 7,84"
G	6x ø9,0mm / 0,35"
H	ø129mm / 5,08"
Inside tunnel dia.	185mm / 7,28"
Max. stern thickness	35mm / 1,38"
Motor output	3,1 KW / 4 HP
Voltage	12 / 24 Volt

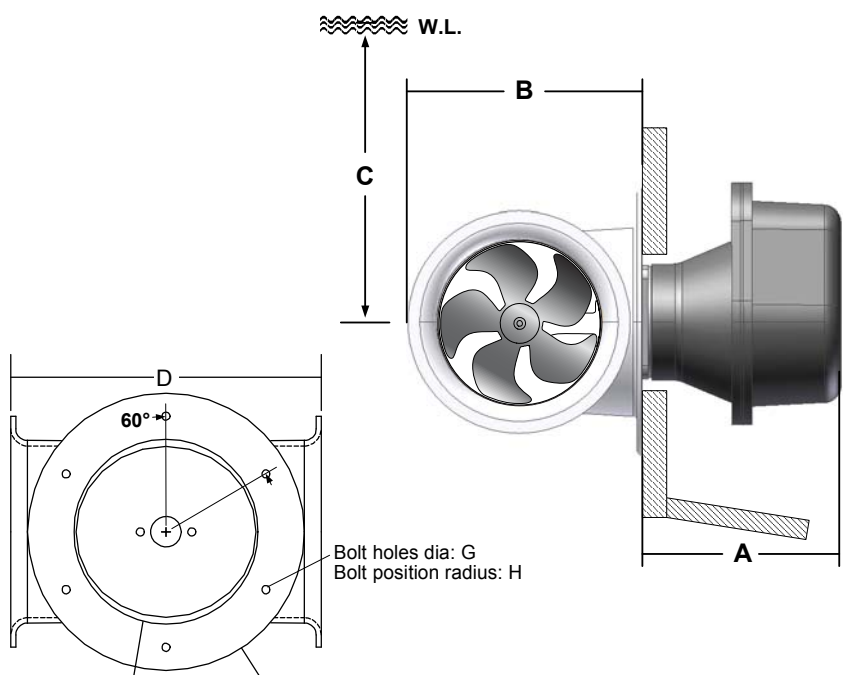

W.L.

B

C

D

60°

Bolt holes dia: G
Bolt position radius: H

Cut out in stern: F

Outside of flange: E

Planning and important precautions

Prior to installation, it is important that the installer reads this guide to ensure necessary acquaintance with this product.

- ⌚ The electromotor assembly must be handled carefully. Do not lift it by the internal connections or put it down on the driveshaft.
- ⌚ Beware to keep installation within advised measurements.
- ⌚ We advice to paint the gearhouse and propellers with antifouling. PS! Do not paint the zinc anodes, sealings or propellershafts.
- ⌚ Do not finish the inside of the tunnel with a layer of gelcoat / topcoat or similiar. It is only room for a thin layer of primer and two layers of anti-fouling between the tunnel and the props.
- ⌚ With the boat on land, only run the thruster for a fraction of a second, as without resistance it will accelerate very fast to a damaging rpm. Also, while the thruster is in air, make sure to avoid direction changes while the thruster is still running, as it might cause damage to the thruster.
- ⌚ This manual is intended to support educated / experienced staff and is therefore not sufficient in all details for the correct installation.
- ⌚ The thruster IP assembly has been tested to be fully ignition protected so that it can be installed in an area with the possibility of explosive gases in accordance to ISO 8846.
- ⌚ Do not install the thruster in a position where you need to cut a stiffener/stringer/support for the hull integrity without checking with the boatbuilder that this can be safely done.
- ⌚ When installed in boats approved or classified according to international or special national rules, the installer is responsible for following the demands in accordance with these regulations / classification rules. The instructions in this guide can not be guaranteed to comply with all different regulations / classification rules.

NB ! Faulty installation of the tunnel, thruster or panel will render all warranty given by Sleipner Motor AS void.

Stern thruster installation considerations

To achieve maximum effect, reliability and durability from your Sidepower stern thruster, a correct installation is very important.

Please follow the instructions carefully, and make sure that all checkpoints are carefully controlled.

Additional considerations for positioning of the stern thruster

- ⌚ Make sure that the stern-tunnel does not disturb the waterflow under the hull
- ⌚ Ensure that when installed the thruster does not foul existing equipment inside the boat like steering links etc.
- ⌚ Make sure that the water flow from the thruster are not interferred to much by sterndrives, trimtabs etc. as this will reduce the thrust considerably.
- ⌚ It is possible to mount the tunnel off the boat's centre line if necessary.
- ⌚ If the stern thickness is to much for the thruster in question you can easily remove hull material in the necessary area to fit the thruster. You only have to reduce the stern thickness down to the max. thickness measurement in the drawing.

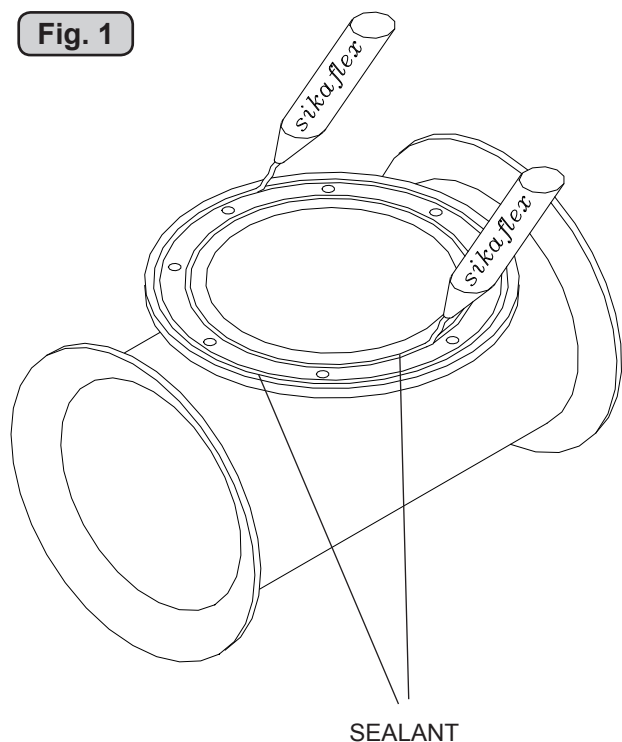
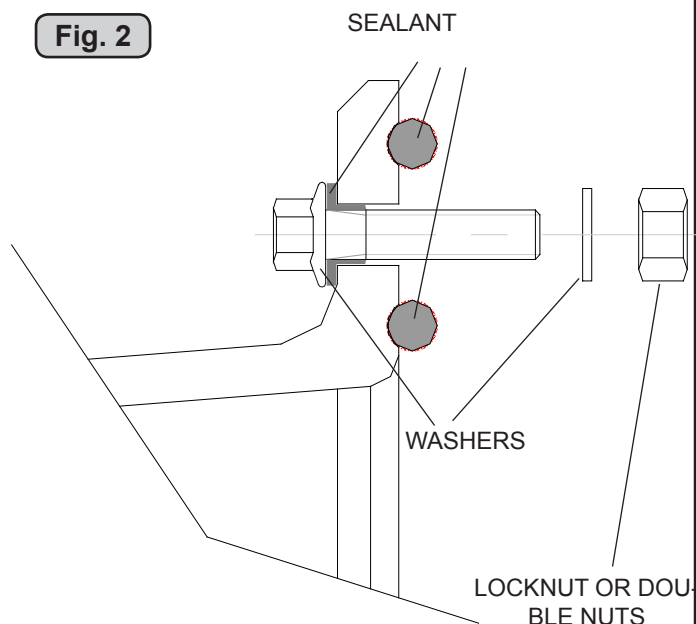
Fig. 1**Fig. 2**

Bolt on installation of the stern tunnel

1. Make sure that there are enough space both inside and outside the transom of the boat.
2. Once the place for the installation has been decided, hold the tunnel in place in the horizontal position and mark the bolt holes. Remove the tunnel and it is then possible to calculate and mark the centre.
3. It is important that the tunnel flange sits flush on the transom. If this is not so, then the area on the transom will have to be flattened to ensure a snug fit.
PS ! Take care with grinders as it is very easy to remove too much in fibreglass
At this time, cut out the centre hole and the transom to the same internal diameter as the tunnel flange and drill the bolt holes. Before bolting on the stern tunnel, the prepared area must be sealed with a gelcoat or similar to ensure there is no water ingress into the hull.
4. Before fitting the tunnel to the transom, fit the lower gear leg to the tunnel as described on page 6. We recommend that you fit the oil feed pipe also before the tunnel is bolted to the transom.
5. When fitting the tunnel, ensure that there is ample sealant (Sikaflex or similar) in the sealing tracks of the tunnel flange and around the bolts to make a water tight fitting (Fig. 1/2). Bolts, washers and nuts are not included as they will vary depending on the transom thickness We recommend A4 stainless with A4 lock nuts and A4 washers of a large diameter on both outside and inside.
Bolts diameter: \varnothing 10mm or 3/8" stainless steel
6. Refer to the installation manual for the recommended thruster fitting.

If a bow thruster is also installed, we strongly advise to use separate battery banks for the two thrusters to avoid extreme voltage drop if both thrusters are to be used at the same time. Refer to the thruster manuals for advised battery capacity and cable sizes for each thruster. Also ensure that you do not have direct connections of both + and - if you have built together controls for both thrusters to avoid current leakage between separate battery banks. If you are installing the standard Sidepower dual joystick panel this is already secured.

Fig. 1

Grind off the bolt flange and the gelcoat both inside and outside in the areas shown.

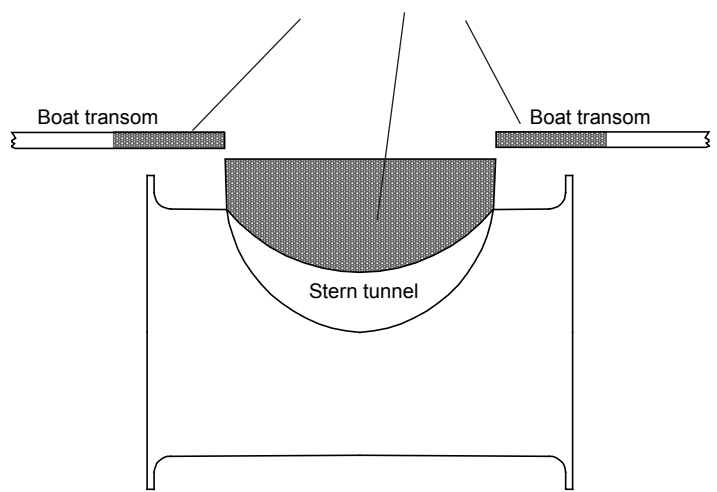
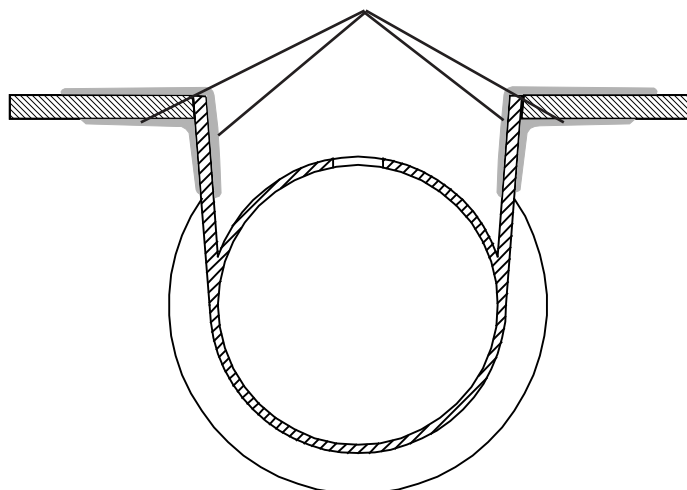

Fig. 2

Bond multiple layers both inside and outside



Mould on installation of the stern tunnel

1. Make sure that there are enough space both inside and outside the transom of the boat.
2. Cut of the bolting flange on the stern-tunnel
3. Grind off the gelcoat both inside and outside the remaining "tube" atleast 10 cm down on the "tube" (Fig. 1).
4. Offer the stern tunnel to the desired position on the transom and mark around the tube.
5. Cut the marked hole in the transom of the boat.
6. Grind off the gelcoat on the transom of the boat in an area of atleast 10 cm / 4" around the hole, both outside and inside (Fig. 1).
7. Offer the stern tunnel to the transom in the desired horizontal position, then bond to the transom with multi layers matt both inside and outside (Fig. 2).
Take care not to reduce the internal diameter much, as this will make it more difficult to mount the thruster
8. Apply gelcoat or similar on all bonded areas.
9. Install the gear leg on the stern-tunnel as described in the installation manual for the thruster but fit the oil feed pipe first.
10. Basic installation of the motor assembly and electrical installation are described later in this manual.

If a bow thruster is also installed, we advice to use seperate battery banks for the two thrusters to avoid extreme voltage drop if both thrusters were to be used at the same time. Refer to the thruster manuals for adviced battery capacity and cable sizes for each thruster. Also ensure that you do not have direct connections of both + and - if you have built together controls for both thrusters to avoid current leakage between seperate battery banks. If you are installing the standard Sidepower dual joystick panel this is already secured.

Fig. 1

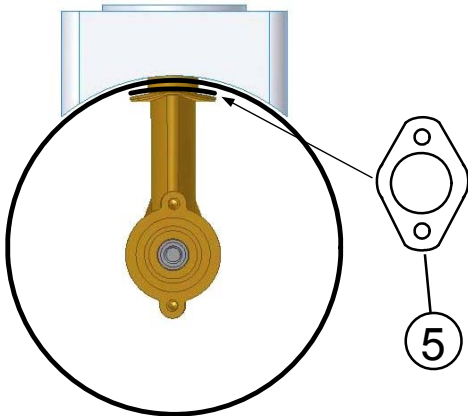
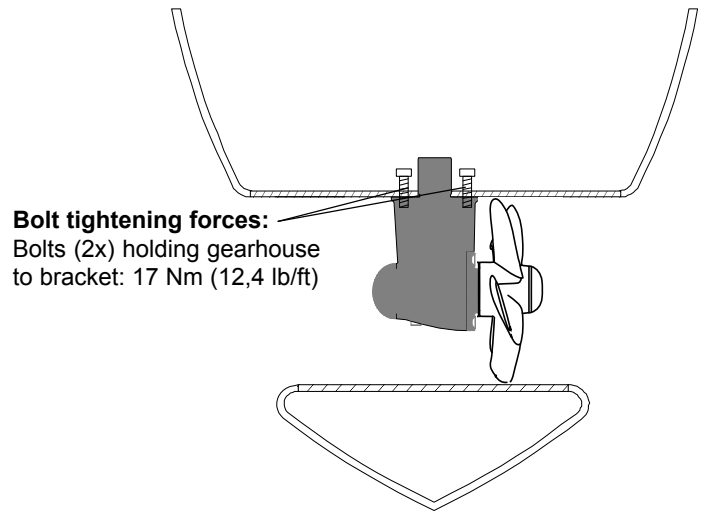

Fig. 2



Fitting gearhouse and motor bracket

1. Try the lower-unit in the tunnel (remove the zinc anode) first by using the gasket inside the tunnel. Try on the propeller to make sure it is centred in the tunnel and turn freely with the same clearance from each blade to the tunnel (Fig. 1).
2. Apply a thin layer of sealant on both sides of the gasket (5) and place it carefully on the gearhouse, making sure no sealant gets into the oil holes or bolt holes on the gearhouse (Fig 1).
3. Push the gearhouse through the main hole in the tunnel and push the gearhouse and motor-bracket gently together.
4. Screw the lower unit and the motor bracket together with the two provided bolts. Tighten with 17 Nm / 12,4 lb/ft (Fig. 2).

Fig. 1

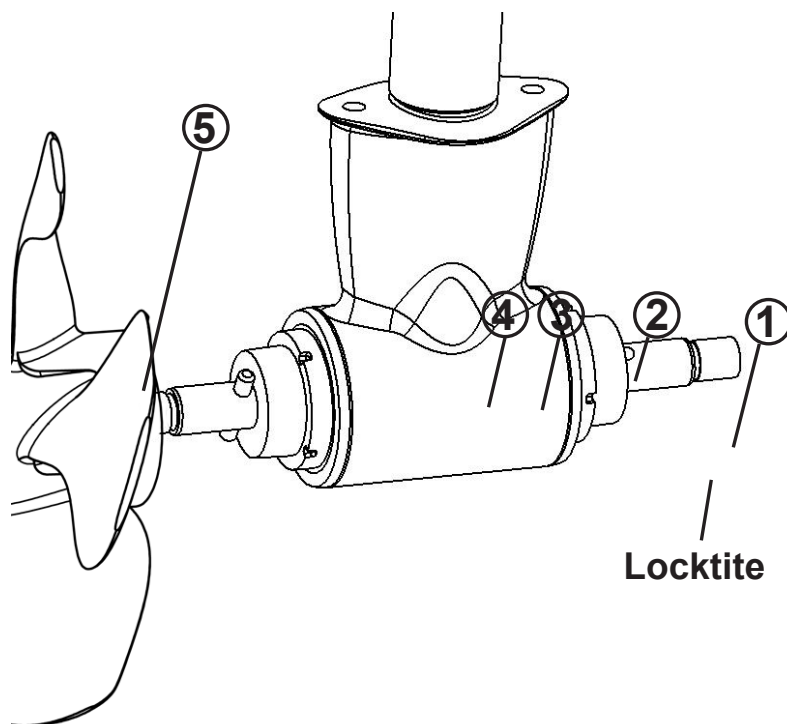

Fitting propellers

1. Turn the propeller shaft so that the drivepin (5) is in a horizontal position and ensure that it is centred in the propellershaft.
2. Push the propeller onto the shaft with the track for the drivepin in an horizontal position (same direction as you set the drivepin), all the way in. There should be almost no gap between the propeller hub and the gearhouse.
3. Place the washer (4) on the prop.shaft and then tighten the lock-nut (3) on the propeller shaft.
4. Place the zincanode (2) in its designated position and tighten the zincanode holding screw (1). Apply a thread glue (Locktite or similar) to ensure that the zincanode holding screw does not un-screw itself from the propellers rotation.

Parts description:

- 1 : Screw for zincanode
- 2 : Zincanode
- 3 : Propeller lock nut
- 4 : Washer
- 5 : Drivepin for propeller

Fig. 1



Fig. 2

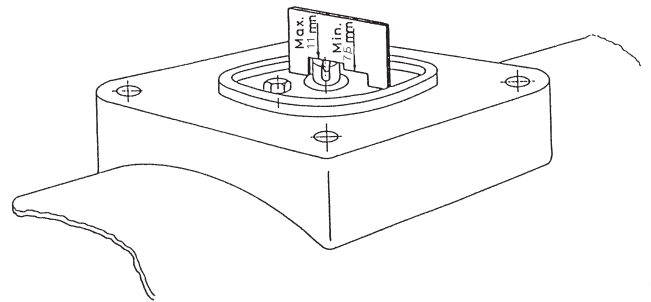

Fitting the electromotor IP assembly

1. Remove the 4 bolts in the motorbracket (Fig 1).
2. Use the enclosed template to measure that the driveshaft has come through the motorbracket with the correct height (Fig 2).
3. Place the motor assembly gently on the motorbracket. Make sure that the drive pin in motor drive shaft fits into the corresponding groove in the gearleg shaft. Be careful, the motor is heavy!
4. Fasten the motor assembly to the bracket with the 4 bolts and cross tighten them first with 15Nm (11lb/ft) and then with 33Nm (24lb/ft).

NB ! Paint the gearhouse and propeller with antifouling for propellers to prevent growth of barnacles or similar which would reduce the performance dramatically. Do not paint the propeller shaft, the zincanodes or the end face of the gearhouse.

NB ! Do not run the thruster for more than very short bursts without being in the water.

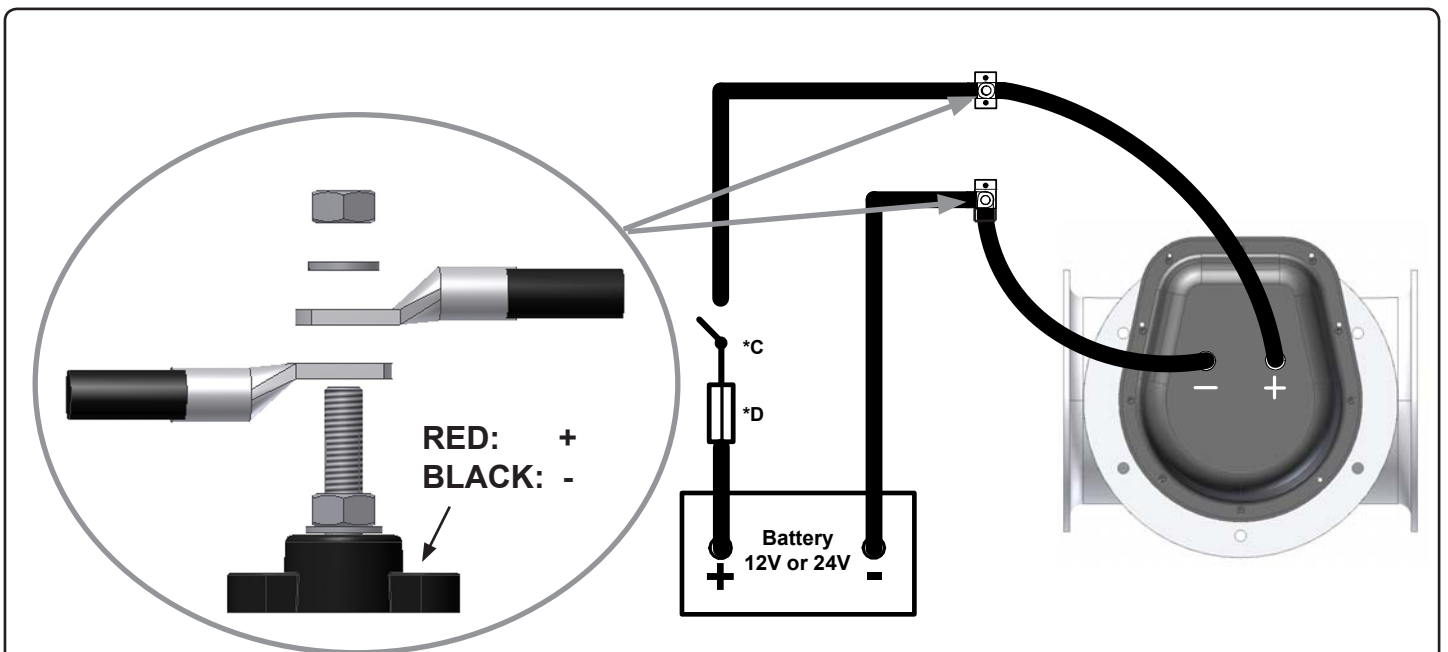

Battery & cable recommendations:

Model	Voltage	Nominal current draw	Min. battery CCA		>7m total + & -		7-14m total + & -		15-21m total + & -		22-28m total + & -		28-35m total + & -		36-45m total + & -	
					Min.	Rec.	Min.	Rec.	Min.	Rec.	Min.	Rec.	Min.	Rec.	Min.	Rec.
SE60/185S	12 V	340 A	DIN: 350 SAE:665	mm ² AWG	35 1	50 1/0	60 2/0	95 3/0	95 3/0	2x 70 2x 2/0	120 4/0	2x95 2x 3/0	2x 95 2x 3/0	2x120 2x 4/0	2x120 2x 4/0	280*
	24 V	170 A	DIN: 175 SAE: 332	mm ² AWG	25 1	35 1	25 1	35 1	25 1	35 1	35 1	50 1/0	50 1/0	60 2/0	60 2/0	70 2/0

Minimum and recommended cable dimensions can be identical due to safety margins and cable heat considerations for short cable lengths.

* Minimum or recommended cable cross section in mm²

Electrical installation

- Explanation of electrical table
 - All cable lengths are the total of + and - (to and from).
 - Battery size is stated as minimum cold crank capacity, not Ah.
 - Use slow fuse rated to hold stated Amp-Draw for min. 5 minutes.
- * Cable size and main battery size when an extra bow battery with minimum the CCA mentioned as A is installed.
- It is important that you use a good cable size and batteries with a high cranking capacity to feed the thruster, because it is the actual voltage at the motor while running the thruster that decides the output rpm of the motor and thereby the actual thrust. Please see the list below for advised min. sizes of cables and batteries. You can of course use larger cables for even better results.
- A main switch (*C) that can take the load without noticeable voltage drop must be installed in the main positive lead so the power for the thruster can be turned off independently of the rest of the system when not on board or in emergencies. This should be placed in an easily accessible place and the boats instructions should include information that this should be turned off like the other main switches of the boat.
- We also advice to install a fuse (*D) in the positive lead for protection against short circuiting of the main cables. This fuse should be of an adequate quality which normally means that it is physically large as these have less voltage drop than the simple / small ones. It should be of the slow type and sized to take the amperage draw for at least 5 minutes.
- Remember to use ignition protected fuses and switches if fitted in areas that require this feature.
- A circuit breaker can be used instead of the fuse and main power switch as long as the functionality is the same.
- The cable ends must be fitted with terminals and these must be well isolated against contact with anything but the proper connection point.
- If the main switch and fuse are installed in the same gas area they also have to be ignition protected.
- The negative / minus cable connects to the (-) terminal. Bolt M10. Tighten with 25 Nm / 18,43 lb/ft.
- The positive / plus cable connects to the "+" terminal. Bolt M10. Tighten with 25 Nm / 18,43 lb/ft.

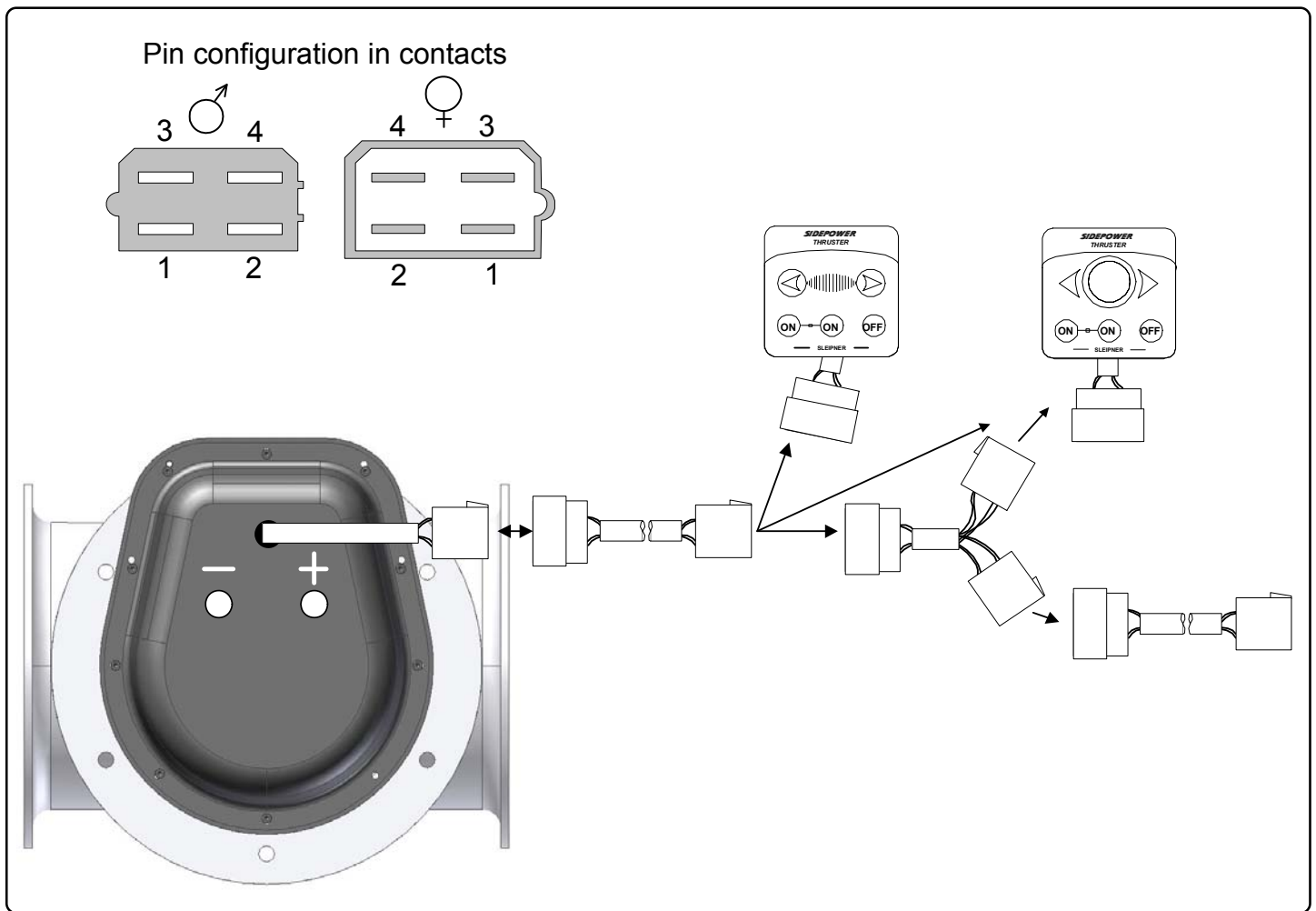

Control panel and control-leads

- You can install as many panels as you wish by using optional Y-connectors. If two or more panels are operated at the same time in opposite directions, the electronic controlbox will stop the thruster until it only receives a signal to go in one direction.
- When using original Sidepower equipment it is all "plug & go".
- If the drive direction of the thruster is the opposite of what expected, the blue and grey wire must be changed on each panel.
- The mechanical installation of the panel is described in the manual following the panel.
- The IP thruster is gas proof based on the control panel lead ending outside of the area that requires ignition protection. The prefitted control lead must be fitted in the boat so there is no risk of damage to the insulation, causing explosive gas penetration.
- The thruster control should be placed in a position where it is easy to use, and it is very common to use the thruster at the same time as your gear / throttle lever so it is normally a user friendly solution to be able to access these with one hand for each control.

Pin configuration of 4 pole AMP contact:

Pin1: BLACK = Ground

Pin2: BLUE = Engages thruster SB solenoid

Pin3: GREY = Engages thruster Port solenoid

Pin4: RED = Positive voltage for control panel

"Visual" wiring diagram

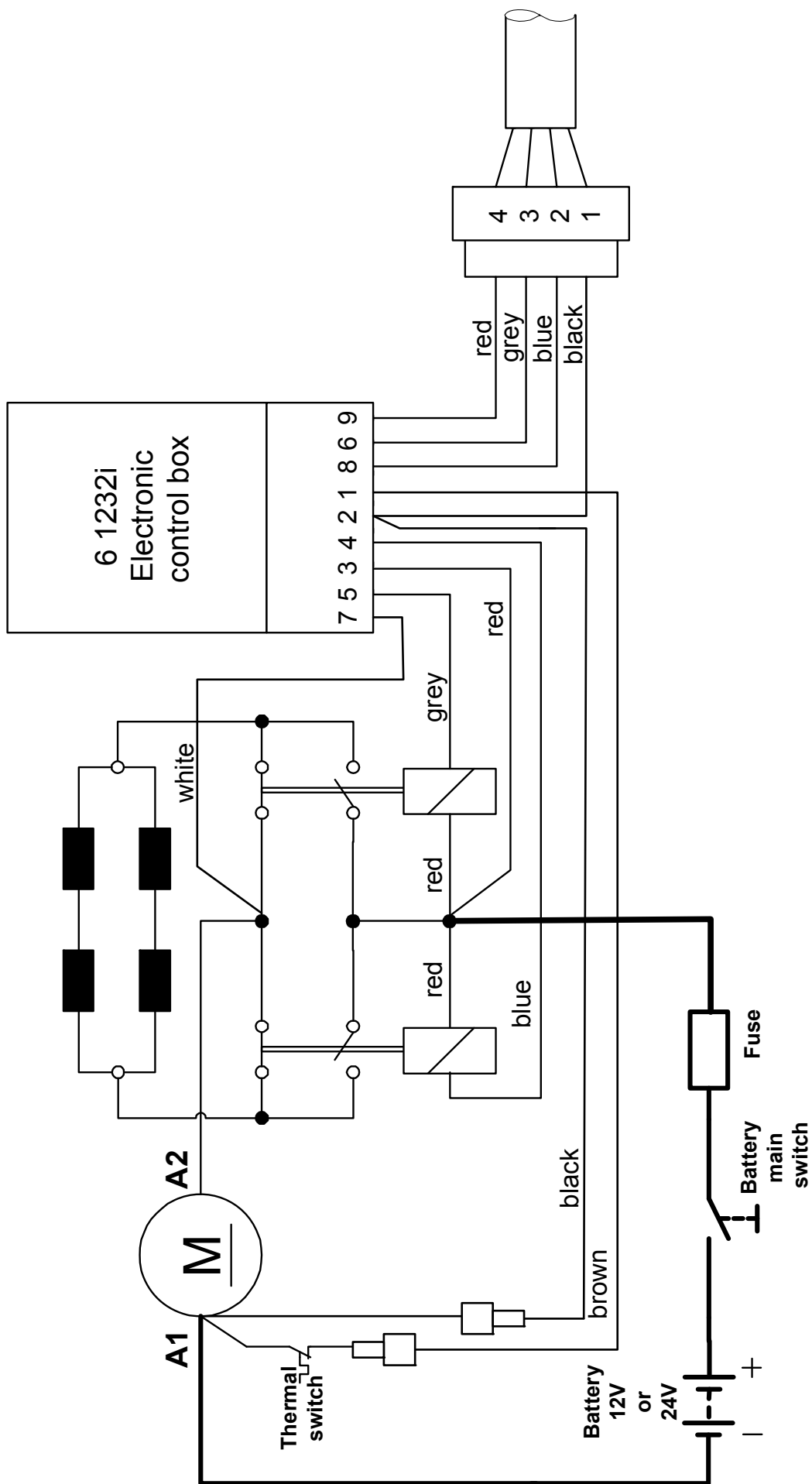

Technical wiring diagram

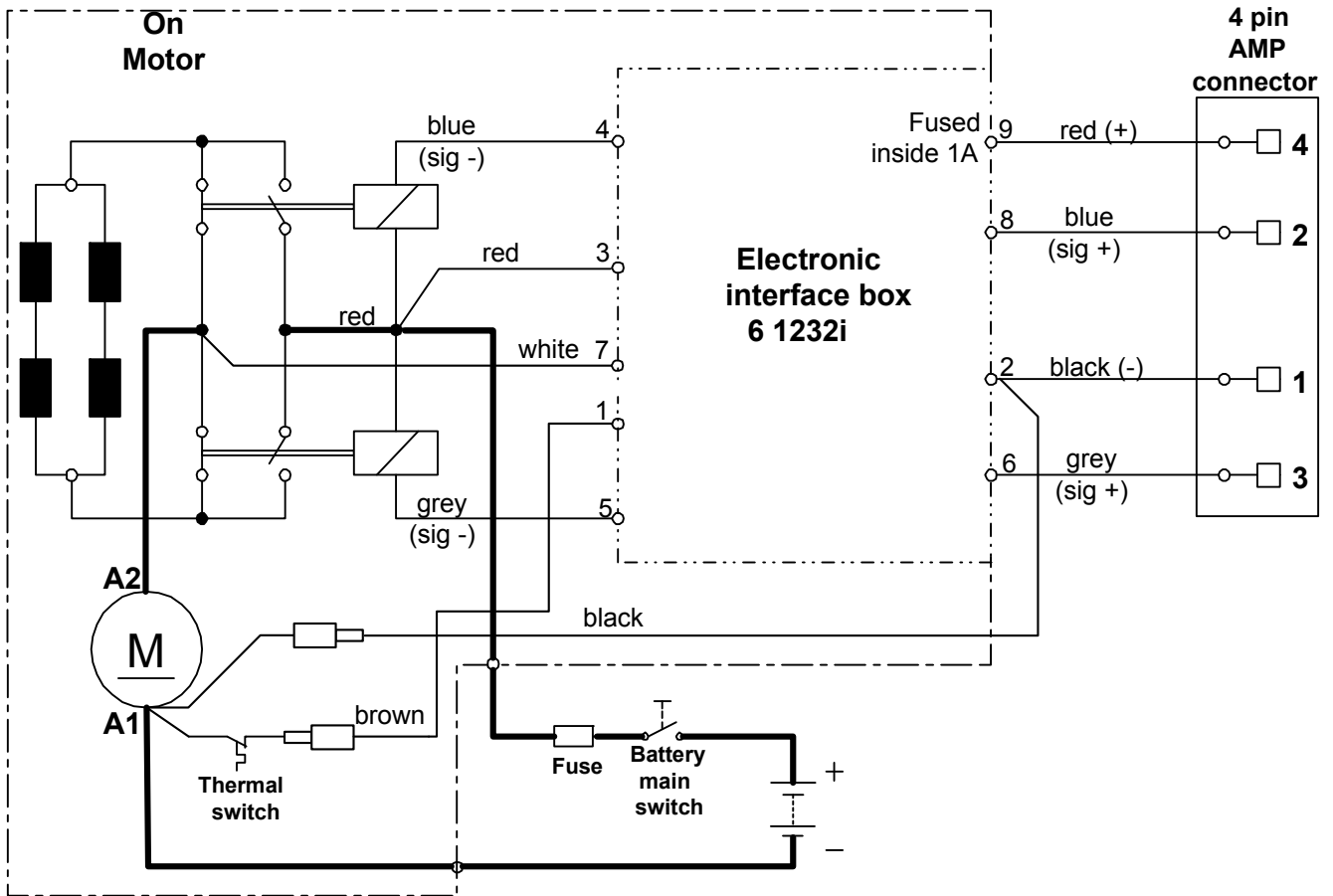

Electrical installation of stern thruster systems

- We advice to use different battery banks for each thruster to ensure maximum performance when both are used at the same time.
- When using the original Sidepower control cables just connect them to the corresponding joystick
- There are no plus/positive power connected from the bowthruster

Visual connection diagram for dual joystick panel

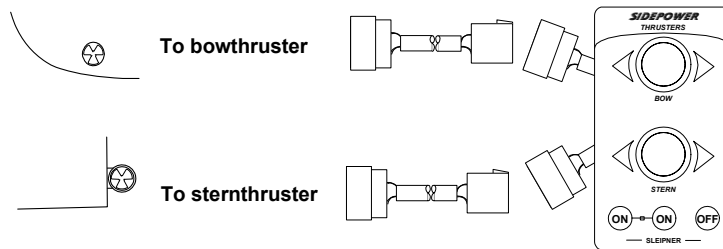

Wiring diagram (simplified) for dual joystick panel

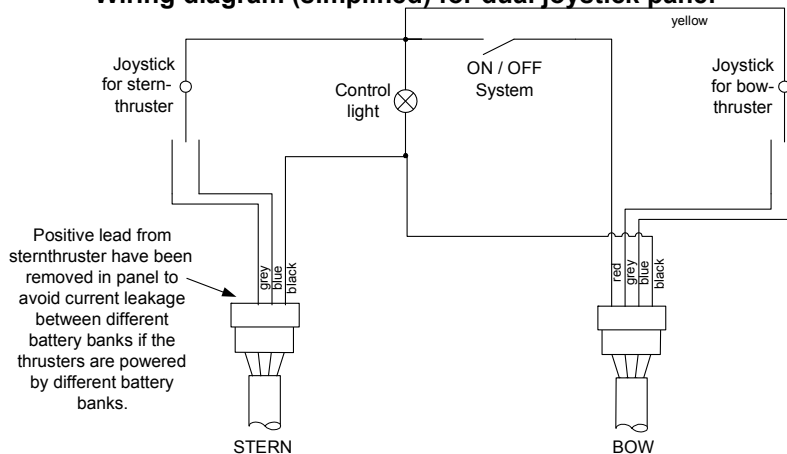

Checklist

- Propeller is fastened correctly to the shaft.
- Propeller turns freely in tunnel.
- The zinc-anode holding screw is tightened well with thread glue.
- There is a sturdy additional support under the electric motor, taking the weight load of the electromotor assembly away from the stern tunnel.
- All electrical wiring, cable sizes and battery capacity is according to the thruster installation manual.
- All bolts are securely tightened and sealant are applied as instructed.
- Anti-fouling have been applied to the gearhouse and propeller but NOT on the zincanode or the gearhouse lid where the propeller is fastened.
- Correct drive direction as per controlpanel.
- All electrical connections are clean, dry and tight, and the correct cable, fuse and main switch sizes have been used.
- The bolts holding the gearhouse and motorbracket together are tightened correctly.

Very important for IP protection:

- The original O-ring seal between the motor assembly and the motor bracket is present and the bolt tightening procedure is done.
- The main power cables have securely been connected as described.
- The control lead ends out of the explosive area and has been properly fitted and secured against damage.

The thruster has been installed as per the instructions in this manual and all points in checklist above have been controlled.

Signed: Date:

Extra pre-delivery tests by installer / yard who does not use other quality control systems !

Thruster type: Voltage:

Serial number:

Date of delivery:

Correct drive direction as per controlpanel:

Voltage at thruster when running:

Battery cable size used:

Other comments by installer:

Important user precautions

- ⌚ Ensure that you know the location and how to operate the main battery switch and that disconnects the thruster from all power sources (batteries) so that the thruster can be turned off in case of a malfunction.
- ⌚ Always turn the main power switch off before touching any part of the thruster, as an incidental start while touching moving parts can cause serious injuries.
- ⌚ Always turn the control device off when the thruster is not in use.
- ⌚ The maximum continuous usage time of the electrical thruster is approximately 3 minutes. The electromotor has a built in thermal cut-off switch that will shut off the electromotor if it is overheating and re-engage it when it has cooled down some. This should be considered when planning your maneuvering.
- ⌚ This also means that the thruster will limit its total running time per time period so that you can not count on the thruster to hold you in a current and sidewind for extensive time periods. Depending on the ambient temperatures etc. the thruster will be able to run approximately 10 % of the time.
- ⌚ Never use a thruster close to somebody in the water, as the thruster will draw objects close by into the tunnel and contact with the rotating propellers will cause serious injuries.
- ⌚ Never run a thruster for more than one second when the boat is not in the water, as this can damage the electromotor seriously.
- ⌚ If the thruster stops giving thrust while the electromotor is running, chances are that there is a problem in the drive-system. You must then immediately stop trying to run it, and turn it off, as running the electromotor for more than a few seconds without resistance from the propeller, can cause serious damage to the electromotor.
- ⌚ When leaving the boat always turn off the main power switch for the thruster.
- ⌚ We advise to always keep the main engine(s) running while using a thruster. This will keep the batteries in a good charge condition. This will also give better performance to the thruster, as a higher voltage at the thruster results in a higher torque (power) in the electromotor.
- ⌚ Please note that the performance of a thruster strongly depends on the voltage available at the electromotor. This voltage will decrease by time because aging batteries have a reduction of capacity. By installing new batteries the effect of the thruster should be back at the original level.
- ⌚ Make sure that only one control is used at the same time, if two panels are operated in opposite directions at the same time the thruster will not run at all. If they are operated in the same direction the thruster will run in this direction.
- ⌚ If the thruster is not performing or functioning as usual, the cause for this must be found and corrected as soon as possible so to avoid causing any other or further damage to the equipment. You must also turn off the main battery switch immediately in case the problem is of electric origin.
- ⌚ To activate the docking control panel, push the two "ON" buttons simultaneously.
- ⌚ The docking control panel shuts off automatically approx. 25 minutes after it was energized. To use the docking control panel later, push the two "ON" buttons simultaneously.
- ⌚ The boat switch is an on/off switch device only that controls your thruster(s). The thruster(s) will run at a constant speed regardless of how hard you pull/push the control switch.

Warning:

- ⌚ **Tampering with the Ignition Protected stern thruster assembly or any attempt to disassemble anything on this thruster assembly inside the boat can cause an explosion with very serious consequences.**
- ⌚ **If there is a problem with your Ignition Protected stern thruster, please contact your dealer.**
- ⌚ **Danger: NEVER Disassemble any part of the Ignition Protected stern thruster assembly**

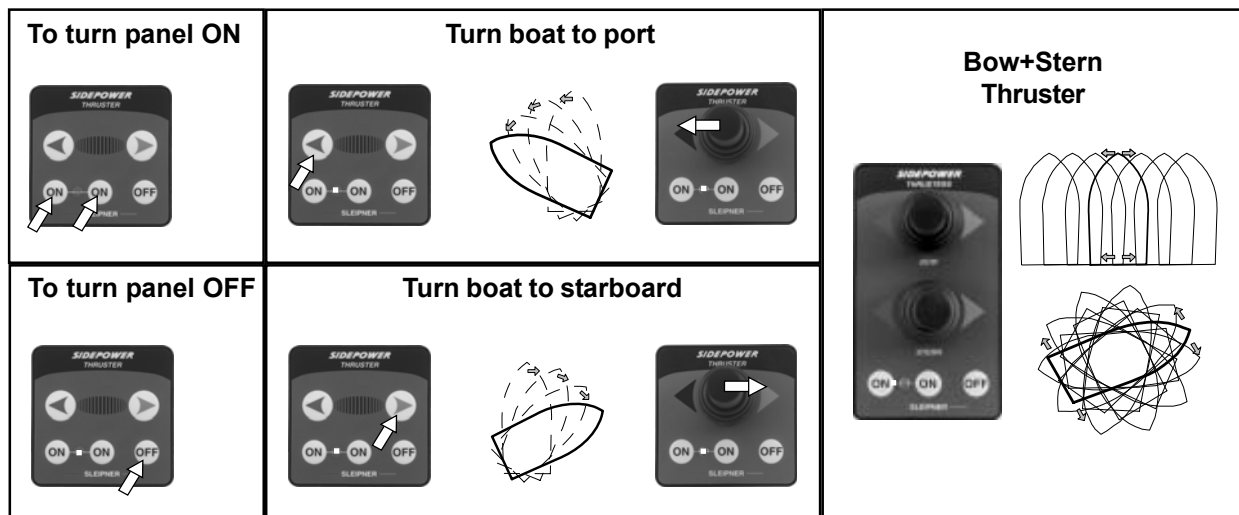

How to use Sidepower thrusters

How to use a bowthruster

1. Turn main power switch for the bowthruster on. (Always turn off the main power switch when not onboard.)
2. Please take some time to exercise thruster usage in open water to avoid damages to your boat.
3. Turn the controlpanel on by pushing both "ON" buttons on the original Sidepower panel simultaneously. If another type of control is installed, engage the On/Off switch for the bowthruster.
4. Turn the bow in the desired direction by pushing the red button for port movement or the green button for starboard movement. If you have a joystick control, move it in the direction you wish the bow to move. Other controls like footswitches or toggle-switches on the throttle can be used. These are normally logically installed, so by engaging the port control, the bow goes port etc. In case of any doubts, try in open waters first.
5. Depending on the sideways speed of the bow, you must disen-gage the control device shortly before the bow is in the desired direction, as the boat will continue to move after stopping the bowthruster.

How to use a single stern thruster

Some boats might however have installed a single stern thruster because of space limitation in the bow. In this case the stern thruster is used in the same way as a single bow thruster (see above) for moving the boat's stern.

How to use a bow and stern thruster combined

The combination of a bow and stern thruster offers total manouverability to the boat and the opportunity to move the bow and the stern separately from each other. This enables you to move the boat sideways in both directions and to turn the boat around it's own axis staying at the same place.

- Again, if in doubt, try in open water first!

- ❶ Electromotor assembly
- ❷ Glassfibre reinforced lexan propeller for ultimate performance.
- ❸ Pre-filled lifetime lubricated gearhouse.
- ❹ Changeable zincanode protects gearhouse from corrosion in seawater.

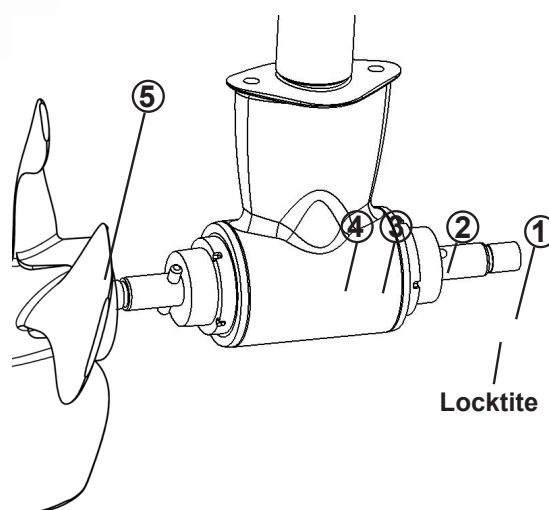
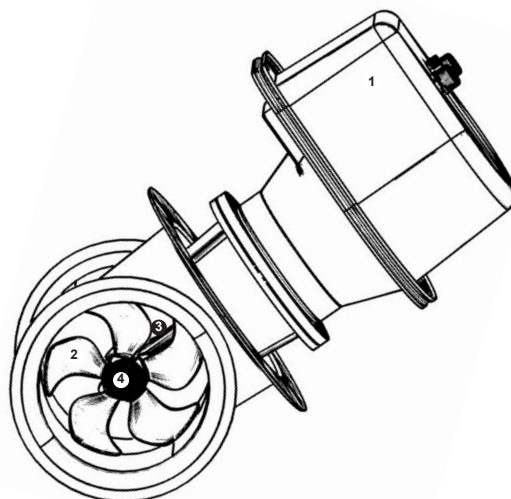

- ❶ Fastening screw for zincanode
- ❷ Zincanode
- ❸ Propeller lock nut
- ❹ Washer
- ❺ Drivepin for propeller

Maintenance

- » Keep the propeller and gearhouse clean from growth by painting with antifouling before every season.
PS ! The zinc anode, sealing and propeller shafts must abso-lutely not be painted. Be careful that you don't fill paint in the "tracks" in the gearhouse that the propeller hub moves in.
- » Change the zinc anode before every season, or when about half the anode is gone. Always use a sealant on the screw holding the zincanode to ensure that it does not fall off. Please observe that in some waterconditions it can be necessary to install an extra zincanode to ensure that it lasts for the whole period between regular service lifts of the boat. Consult your dealer for information on how to do this.
- » As a part of the seasonal service of your boat, and before every season, always check that:
 - The propeller is securely fastened
 - The bolts holding the electric motor to the motorbracket are fastened correctly.
 - The area where the thruster is installed is clean and dry. If there are signs of water you must try to find the source and eliminate it.
 - All electrical connections are clean and fastened firmly.
 - Make sure that your batteries are in a good condition so that the thruster gets a good voltage. Old or bad batteries will give a reduced performance from the thruster.

Warning:

- ⚠ **Tampering with the Ignition Protected stern thruster assembly or any attempt to disassemble anything on this thruster assembly inside the boat can cause an explosion with very serious consequences.**
- ⚠ **If there is a problem with your Ignition Protected stern thruster, please contact your dealer.**
- ⚠ **Danger: NEVER Disassemble any part of the Ignition Protected stern thruster assembly**

Troubleshooting

Before seeking assistance at the help desk of your Sidepower dealer / distributor please perform these tests and make notes of all measurements to ensure that they have as much information as possible to work on.

NB! All check points and solutions must be carried out after consulting the relevant information elsewhere in this manual to understand how the system is intended to work. If you are unable to understand what to check, you must consult a professional.

Check

Solution

» **The electromotor runs, but there is no thrust.**

If the flexible coupling between the motor and driveshaft is not fitted correct inside the boat

Check the flexible coupling and the motor installation to ensure correct connection of the flexible coupling before re-fitting the electromotor

Are the propellers in the tunnel fastened correctly on the prop-shaft (key present)

Re-fasten or replace the propeller and/or key.

With the motor removed, turn the driveshaft from inside the boat to feel if the gears are engaging and turning the prop-shaft.

In case of a failure inside the gearhouse, we advice to get a replacement gear-house instead of attempting to repair the internal gear and bearing system.

» **The thruster does not start at all or works only in one direction.**

Check that the voltage of the electromotor are correct for your installation by their labels.

If wrong, contact your dealer or distributor to obtain parts with the correct voltage.

Check the voltage at the thruster between main minus input (A1 on motor) and main plus input point:

The no load voltage should be:
12V system = 12,7V / 24V system = 25,4 V. If below 12,3V / 24,6V your batteries are not in a good charge state or worn out and must be recharged or replaced before trying to run the thruster.

Check the voltage at the thruster while you are trying to run it. Keep main engine(s) running to have continuous charge to the batteries.

If less than 8,5V at the thruster the voltage is too low for the thruster to operate correctly. In a 24V boat the thruster will operate down to approx. 12V, but the performance will be very bad. Find and correct the reason for this low voltage which will probably be one or more of these points: main battery cable sizes and connections, battery size and condition, fuse and main power switch performance.

If the main solenoids on the thruster are not even trying to engage (clicking) they are probably not getting a "run" signal from the control system. Try to run the thruster without the panel by directly connecting the red and the blue or the red and the grey wires in the control cable contact coming from the thruster.

If the thruster runs in both directions, try the same in the connector that goes into the back of the control panel. If it also works in this position, check the contact and wires on the back of the panel and try to engage this again by pushing both ON buttons simultaneously. If the panel does not turn on (see control light), measure the voltage between the Red and the Black in the contact going into the thruster. If the voltage is good, chances are that the panel is not working. If it works by the thruster, and not by the panel there is a bad contact or a broken lead the control cables between these two test points. Measure that you have the correct voltage between the Red (+) and all the other colours in the contact. If you do not get a reading.

If the thruster does not run at all, or only in one direction in the above tests, check the internal wiring on the thruster motor, solenoids and electronic motor inter-face box to be in accordance with the wiring diagram and ensure that all connections are clean and tight.

Between main minus (A1 on motor) and the blue and the grey wire connected to the sides of the main solenoids you should have the same voltage as between the main battery cables on the thruster. If not, check that the internal wiring on the solenoid is ok and measure that there is contact through the magnetising spools of each side of the solenoid (measure between the red and blue on one side, and red and grey on the other side with an Ohm meter.). If there are no contact between these, the solenoid is broken and needs replacing.

» **The thruster has an unexpected low performance.**

Check voltage at thruster when running

If less than 10,5 V / 21V the thruster will not perform at specified effect.

Check that all the brush-springs sits correctly on the brushes in the electromotor.

If one or more brushes are loose/has no tension from the brush-spring, the performance will be low.

Check that the propeller, gearhouse and tunnel is free from growth / barnacles etc.

If there are growth in the tunnel, this will disturb / block the waterflow and especially barnacles on the propeller will greatly reduce performance.

» **The thruster runs for approximately 0,5 seconds every 4 seconds.**

Solenoid flapping, most probable cause: low voltage.

Re-charge battery(ies), if this is not sufficient, replace battery(ies). Check for bad cable connections, if necessary tighten/re-adjust connections. Check cable size in accordance to manual.

» **The thruster runs for approximately 0,5 seconds every 10 seconds.**

Solenoid lock-in, auto stop of thruster, auto retry every 10 seconds.

Shut off thruster main switch, tap slightly on the solenoid to see if it will release. Turn on thruster main switch. If solenoid is still in lock-in mode, replace solenoid.

Warranty statement

1. The equipment manufactured by Sleipner Motor AS (The "Warrantor") is warranted to be free from defects in workmanship and materials under normal use and service.
2. This Warranty is in effect for of two years from the date of purchase by the user. Proof of purchase must be included, to establish that it is inside the warranty period.
3. This Warranty is transferrable and covers the product for the specified time period.
4. In case any part of the equipment proves to be defective, other than those parts excluded in paragraph 5 below, the owner should do the following:
 - (a) prepare a detailed written statement of the nature and circumstances of the defect, to the best of the Owner's knowledge, including the date of purchase, the place of purchase, the name and address of the installer, and the Purchaser's name, address and telephone number;
 - (b) the Owner should return the defective part or unit along with the statement referenced in the preceding paragraph to the warrantor, Sleipner Motor AS or an authorized Service Centre, postage/shipping prepaid and at the expense of the Purchaser;
 - (c) if upon the Warrantor's or Authorized Service Centre's examination, the defect is determined to result from defective material or workmanship, the equipment will be repaired or replaced at the Warrantor's option without charge, and returned to the Purchaser at the Warrantor's expense;
 - (d) no refund of the purchase price will be granted to the Purchaser, unless the Warrantor is unable to remedy the defect after having a reasonable number of opportunities to do so. Prior to refund of the purchase price, Purchaser must submit a statement in writing from a professional boating equipment supplier that the installation instructions of the Installation and Operation Manual have been complied with and that the defect remains;
 - (e) warranty service shall be performed only by the Warrantor, or an authorized Service Centre, and any attempt to remedy the defect by anyone else shall render this warranty void.
5. There shall be no warranty for defects or damages caused by faulty installation or hook-up, abuse or misuse of the equipment including exposure to excessive heat, salt or fresh water spray, or water immersion except for equipment specifically designed as water-proof.
6. No other express warranty is hereby given and there are no warranties which extend beyond those described in section 4 above. This Warranty is expressly in lieu of any other expressed or implied warranties, including any implied warranty of merchantability, fitness for the ordinary purposes for which such goods are used, or fitness for a particular purpose, and any other obligations on the part of the Warrantor or its employees and representatives.
7. There shall be no responsibility or liability whatsoever on the part of the Warrantor or its employees and representatives for injury to any person or persons, or damage to property, loss of income or profit, or any other consequential or resulting damage or cost which may be claimed to have been incurred through the use or sale of the equipment, including any possible failure or malfunction of the equipment, or part thereof.
8. The Warrantor assumes no liability for incidental or consequential damages of any kind including damages arising from collision with other vessels or objects.
9. This warranty gives you specific legal rights, and you may also have other rights which vary from country to country.

Original model	SE 60/185 S IP		
	09/07 <		
Model period	Part #		
Ref:	12V	24V	
28	Complete Ignition Protected electric motor assembly	4 0102 12	4 0102 24
27	Nut for solenoid cover	N/A	N/A
26	Solenoid Cover	N/A	N/A
25	Complete solenoid kit	N/A	N/A
24	Solenoid	N/A	N/A
23	Internal wiring loom	N/A	N/A
22	Electronic control box	N/A	N/A
21	Solenoid bracket kit	N/A	N/A
20	Shearpin for electric motor shaft	4 2050	4 2050
19	Gasket	N/A	N/A
18	Electric motor	N/A	N/A
17	Brush springs for motor (kit)	N/A	N/A
16	Brushes for motor (kit)	N/A	N/A
13	Complete motor bracket	4 0501	4 0501
11	Complete gearleg	4 0602	4 0602
10	Gearleg bolt	6 1080	6 1080
9	Drive shaft seal	7 1350	7 1350
8	Propeller shaft seal	6 1350	6 1350
7	Gasket	4 0610	4 0610
5	Zink anode	7 1190	7 1190
4	Locknut	4 1260	4 1260
3	Propeller washer	7 1181	7 1181
2	Propeller drivepin	6 1241	6 1241
1	Propeller	4 1261	4 1261

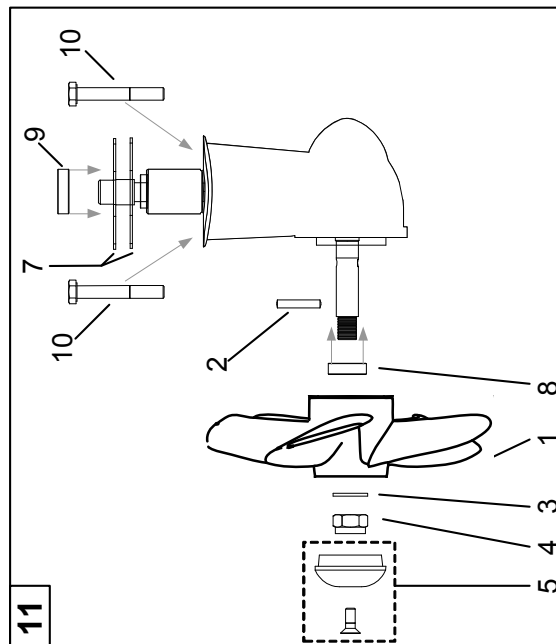
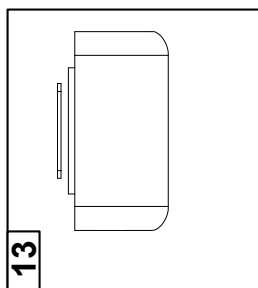
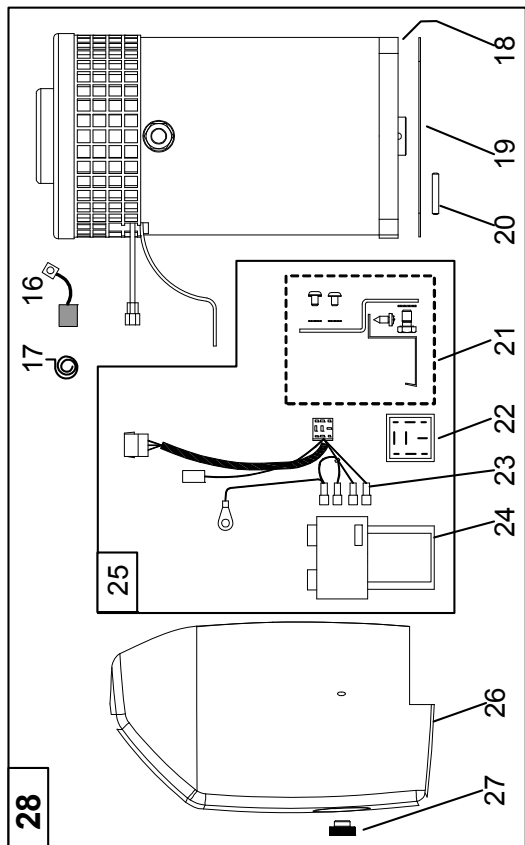

Service Centres

Argentina

Trimer SA
Buenos Aires
Tel: +54 11 4580 0444
Fax: +54 11 4580 0440
www.trimer.com.ar
trimer@trimer.com.ar

Australia

AMI Sales
Freemantle, WA
Tel: +61 89 331 0000
Fax: +61 89 314 2929
ami@amisales.com.au

Austria

G. Ascherl GmbH
Hard, Bregenz
Tel: +43 5574 899000
Fax: +43 5574 89900-10
www.ascherl.at
office@ascherl.at

Benelux

ASA Boot Electro
Watergang
Tel: +31 20 436 9100
Fax: +31 20 436 9109
www.asabootelectro.nl
info@asabootelectro.nl

Brazil

Electra Service Ltda.
Guaruja
Tel: +55 13 3354 3599
Fax: +55 13 3354 3471
www.electraservice.br.com
albertoni@electraservice.com.br

Bulgaria

Yachting BG
Burgas
tel: +359 56 919090
fax: +359 56 919091
www.yachting.bg
info@yachting.bg

Canada

Imtra Corporation
New Bedford, MA
Tel: +1 508 995 7000
Fax: +1 508 998 5359
www.imtra.com
side-power@imtra.com

China/Hong Kong

Storm Force Marine Ltd.
Wanchai, Hong Kong
Tel: +852 2866 0114
Fax: +852 2866 9260
www.stormforcemarine.com
sales@stormforcemarine.com

Croatia

AC Yacht & nautical support
Icici
Tel: +385 51 704 500
Fax: +385 51 704 600
acy@net.hr

Denmark

Gertsen & Olufsen AS
Hørsholm
Tel: +45 4576 3600
Fax: +45 4576 1772
www.gertsen-olufsen.dk
info@gertsen-olufsen.dk

Finland

Nautikulma OY
Turku
Tel: +358 2 2503 444
Fax: +358 2 2518 470
www.nautikulma.fi
nautikulma@nautikulma.fi

France

Kent Marine Equipment
Nantes
Tel: +33 240 921 584
Fax: +33 240 921 316
www.kent-marine.com
contact@kent-marine.com

Germany

Jabsco GmbH
Norderstedt
Tel: +49 40 535 373-0
Fax: +49 40 535 373-11

Greece

Amaltheia Marine
Athens
Tel: +30 210 2588 985
Fax: +30 210 2588 986
www.amaltheiamarine.com
amalmar@otenet.gr

Iceland

Maras EHF
Reykjavik
Tel: +354 555 6444
Fax: +354 565 7230
www.maras.is
gummi@maras.is

India

Indo Marine Engineering Co. Pvt. Ltd
Pune, Maharashtra
Tel: +91 20 2712 3003
Fax: +91 20 2712 2295
siddharth@indogroup-asia.com

Ireland

Sleipner Motor Ltd.
South Brent
Tel: +44 1364 649 400
Fax: +44 1364 649 399
andy@sleipner.co.uk

Israel

Atlantis Marine Ltd.
Tel Aviv
Tel: +972 3 522 7978
Fax: +972 3 523 5150
www.atlantis-marine.com
atlantis@inter.net.il

Italy

Saim S.P.A.
Assago-Milan
Tel: +39 02 488 531
Fax: +39 02 488 254 5
www.saim-group.com

Japan

Turtle Marine Inc.
Nagasaki
Tel: +81 95 840 7977
Fax: +81 95 840 7978
www.turtle-marine.com
info@turtle-marine.com

Malta

S & D Yachts Ltd.
Cali
Tel: +356 21 339 908
Fax: +356 21 332 259
www.sdyachts.com
info@sdyachts.com

New Zealand

Advance Trident Ltd.
Auckland
Tel: +64 9 845 5347
Fax: +64 9 415 5348
www.advancetrident.com
service@advancetrident.com

Norway

Sleipner Motor AS
Fredrikstad
Tel: +47 69 30 00 60
Fax: +47 69 30 00 70
www.side-power.com
sidepower@sleipner.no

Poland

Taurus Sea Power SP. Z.O.O
Gdansk
Tel: +48 58 344 30 50
Fax: +48 58 341 67 62

Portugal

Krautli Portugal Lda.
Lisboa
Tel: +351 21 953 56 00
Fax: +351 21 953 56 01
www.krautli.com
contact@krautli.pt

Russia

Standarte
Starbeyevo
Tel: +7 495 575 67 23
Fax: +7 495 575 39 77
www.standarte.ru
info@standarte.ru

Spain

Imnasa Marine Products
Girona
Tel: +34 902 300214
Fax: +34 902 300215
www.imnasa.com
imnasa@imnasa.com

Sweden

Sleipner AB
Strömstad
Tel: +46 526 629 50
Fax: +46 526 152 95
www.sleipnerab.se

Switzerland

Marine Parts Technics AG
Volketswil
Tel: +41 1 997 40 90
Fax: +41 1 997 40 94
www.marineparts.ch
info@marineparts.ch

Singapore

Alquest Marketing
Singapore
Tel: +65 6749 9359
Fax: +65 6749 9360
www.alquest.com.sg
alquest@singnet.com.sg

Singapore/Malaysia/ Indonesia/Vietnam/Philippines

OK-Maritime Pte Ltd
Singapore
Tel: +65 9669 8051
Fax: +65 6769 0507
www.ok-maritime.com
sales@ok-maritime.com

Taiwan

Mercury Marine Supply
Kaohsiung
Tel: +886 7 3317 293
Fax: +886 7 3314 232

Turkey

Denpar Ltd.
Istanbul
Tel: +90 212 285 0334
Fax: +90 212 285 0311
bilgebay@superonline.com

UK

Sleipner Motor Ltd.
South Brent
Tel: +44 1364 649 400
Fax: +44 1364 649 399
andy@sleipner.co.uk

United Arab Emirates

Teignbridge Propellers & Marine
Equipment Co. Ltd.
Dubai
Tel: +971 4 324 0084
Fax: +971 4 324 0153
teignpro@emirates.net.ae

USA

Imtra Corporation
New Bedford, MA
Tel: +1 508 995 7000
Fax: +1 508 998 5359
www.imtra.com
side-power@imtra.com

All other:

Sleipner Motor AS

